



● **Features:**

- Standard slim model, height 30mm
- The parallel and current sharing technology
- -20~+70°C working temperature (refer to derating curve)
- Protections: short circuit/overload/over voltage
- 100% full load burn-in test
- High efficiency, High reliability
- 2 years warranty

- **Applications:** LED display、LED indicator light、LED TV wall and so on.

● **Standard**

EN55024\EN61000-4-2,3,4,5,6,8,11\GB17625.1\EN61000-3-2,-3\EN55022\GB4943\UL1012

● **Product description**

A-200AF-N is Led display power supply without fans. The input voltage rang is 180~264VAC and output voltages are 2.8V、3.3V、3.8V、4.2V、4.5V、5V. It can be applied to Led display、LED indicator light and other Led display fileds. This series product is ultra-thin design, with a height of only 30mm, and can adapt to a variety of box size requirements. Super high efficiency, compact shell design and good heat dissipation ensure the long-term stable work of this series of products.

● **产品命名**

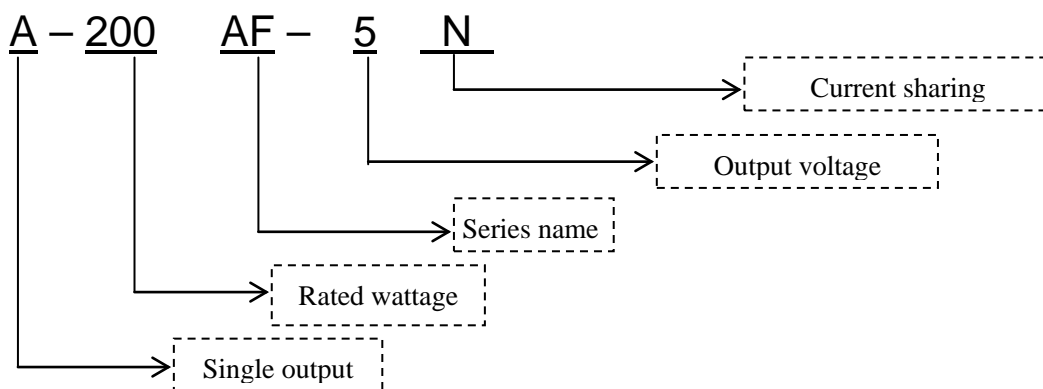

● SPECIFICATION

Model		A-200AF-2.8N	A-200AF-3.3N	A-200AF-3.8N	A-200AF-4.2N	A-200AF-4.5N	A-200AF-5N
Input	Voltage range	180~264VAC					
	Input current	230VAC/2.5A					
	Efficiency	≥82%	≥84%	≥86%	≥86%	≥86%	≥88%
	Frequency range	47~63HZ					
	Leakage current	<1mA/240VAC					
	Inrush current	Cold start 60A/230VAC					
Output	DC voltage	2.8V	3.3V	3.8V	4.2V	4.5V	5V
	Rated current	40A	40A	40A	40A	40A	40A
	Power	112W	132W	152W	160W	180W	200W
	Voltage adj.range	±3.0%	±3.0%	±3.0%	±3.0%	±3.0%	±3.0%
	Ripple and noise	150mVp-p	150mVp-p	150mVp-p	150mVp-p	150mVp-p	150mVp-p
	Set up, rise time	2000ms, 50ms/230VAC 100% load					
	Hold up time	20ms/230VAC 100% load					
	Line regulation	±0.5%	±0.5%	±0.5%	±0.5%	±0.5%	±0.5%
	Load regulation	±2.0%	±2.0%	±2.0%	±2.0%	±2.0%	±2.0%
	Voltage tolerance	±2.0%	±2.0%	±2.0%	±2.0%	±2.0%	±2.0%
EMC	EMS	Design refer to:EN55024 ;EN61000-4-2,3,4,5,6,8,11					
	Harmonic current	Design refer to:GB17625.1;EN61000-3-2,-3					
	EMC	Design refer to:EN55022, Class A					
Safety	Safety standard	Design refer to:GB4943/UL1012					
	Withstand voltage	I/P-O/P:1.5KVac/10mA; I/P-CASE:1.5KVac/10mA; O/P-CASE:0.5KVDC/10mA Testing time:1min					
	Isolation resistance	I/P-O/P: 50M ohms; I/P-Case:50M ohms; O/P-Case:50M ohms					
Protection	Over Voltage	Voltage limited, 110%~140% rated voltage					
	Over load	110~150% rated Hiccup mode, recovers automatically after fault condition is removed					
	Over Temperature	/					
	Short circuit	Power supply protection after short circuit, and output can be recovered automatically after eliminating short circuit					
Environment	Working temperature and humidity	-20~70°C 20%~95%RH no condensing (refer to derating curve)					
	Storage temperature and humidity	-40°C~85°C; 10%~95% RH no condensing					
	Vibration	10~500Hz,2G, 10min/1 cycle,60min.each along X,Y, Z axes					
	Impact	Acceleration: 20g, duration: 11ms, 3 impacts along X, y, Z axis					
	Altitude	the ambient temperature derating of 0.6 %/100m for operating altitude higher than 2000m					
Reliability	MTBF	25 250000Hrs, MIL-217 Method					
Others	Size	190*82*30 mm (L*W*H)					
	Packing	0.36Kg/piece,30pieces/carton, 12KG/carton					
	Cooling mode	<input checked="" type="checkbox"/> Free air <input type="checkbox"/> Fan					
	More options	<input type="checkbox"/> PCB double side conformal coating <input type="checkbox"/> terminal cover <input type="checkbox"/> Low temperature start (-40°C) <input type="checkbox"/> Others					
Note	*In order to extend the lifetime, it is recommended to configure the load more than 30% of the remaining allowance. For example: the power of the device requires 100W, then use the power of not less than 130W. *Ripple test method: 20MHz oscilloscope in power output terminal test, oscilloscope probe wire length is not more than 12mm, and input parallel 47uF electrolytic capacitors and 0.1uF high frequency capacitance probe. *All electrical performance tests are performed at 25 C. *When the product is used in full load, the aluminum plate with an area of 400 * 400 * 3mm shall be added for auxiliary heat dissipation. *The power supply is a part of the components of the equipment system. All EMC tests are conducted by installing the sample on the metal plate. The power supply shall be confirmed with the terminal equipment for electromagnetic compatibility.						

● **Installation**

Warning

- Using the mounting screws M3*6mm,
- Deep housing screw depth Max 4mm,
- As shown on the right

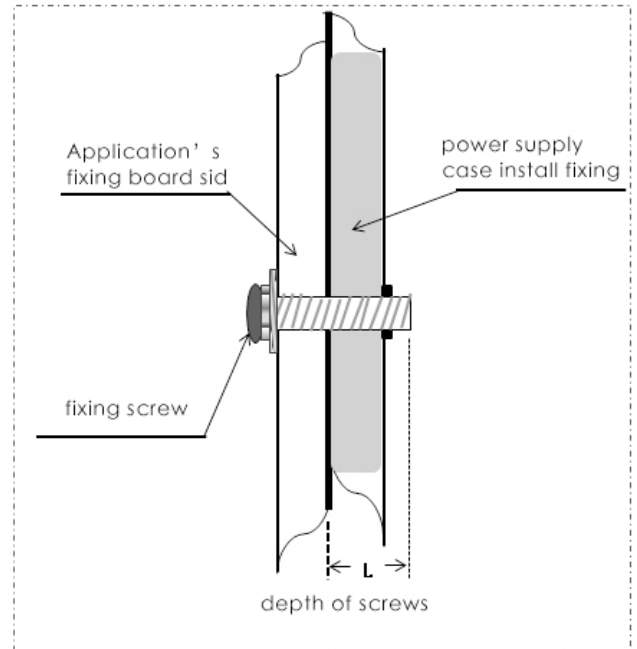

● **Product installation and Instructions:**

- 1、 When installing, please follow the mechanical size and installation method.
- 2、 Before commissioning, please check and proofread the connections on the terminals to make sure that the input and output, AC and DC, positive and negative poles, voltage and current values are correct, to prevent the occurrence of reverse connection errors and to avoid damage to power supply and user equipment.
- 3、 Please use the multimeter to measure whether the fire line, zero line and ground line are short-circuited and whether the output terminal is short-circuited before power is turned on.
- 4、 Do not exceed the nominal value of the power supply in use, so as to avoid affecting the reliability of the product. If you need to change the output parameters of the power supply, please consult the technical department of our company before using the power supply to ensure the effectiveness and reliability of the use.
- 5、 To ensure safety and reduce interference, ensure reliable grounding of grounding end (grounding wire>AWG18#).
- 6、 If the power supply fails, please do not repair it without authorization. Please contact our customer service department as soon as possible. Customer service line:86-519-85210050.

● **Transport and storage:**

1、 Transport:

This packing is suitable for transportation of automobiles, ships, airplanes and trains. It should be rainproof and handled civilly during transportation.

2、 Storage:

When the product is not in use, it should be placed in the packing box. The storage environment temperature and relative humidity should meet the requirements of the product. There should be no corrosive gas or products in the warehouse, and there should be no strong mechanical vibration, impact and strong magnetic field. Packing box should be at least 20 cm high from the ground, do not allow water immersion. If the storage time is too long (more than one year), it should be re-examined by professionals before it can be used.